

## Instruction

# TU-UV

## OmniGuard portable UV test unit



**Article number:**

**43808-3**



## INSTRUCTION Article number: 43808-3

### GENERAL

The portable UV Test Unit is designed to check the operation of Omniguard UV Fire Detector Heads without the hazard of open flame.

The unit is composed of a high intensity UV source powered by three nickel-cadmium rechargeable batteries which may be charged from any 100-240, 50/60 Hz power source, with Firefly charger P/N 24129. It is capable of activating the UV Fire Detectors from a distance of 30 feet in direct line of sight, or 26 feet at any angle of 30° from the detector centerline.



### OPERATION

**NOTE:** Disconnect any fire extinguishing circuits controlled by the detector before activating the test unit.

**WARNING!! DO NOT LOOK INTO THE LENS OF THE TEST UNIT WHILE IT IS LIGHTED.**

1. Make sure both end caps are secure with all threads engaged, and all set screws tight.

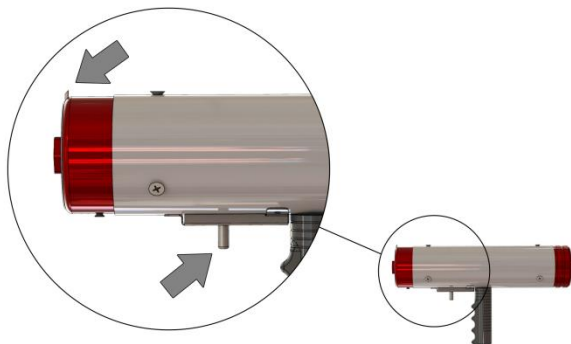

2. While aiming the test unit at the detector, look at the test unit pilot lens located at the top of the front cap and depress the trigger switch. The pilot lens will indicate illumination of the UV source lamp.

3. Standing on the viewing axis of the detector (a line from the center of the detector and at right angles to its front) and at the limit of the protected area, aim the test unit at the detector and depress the trigger switch. The detector should alarm within the time specified for the installation.

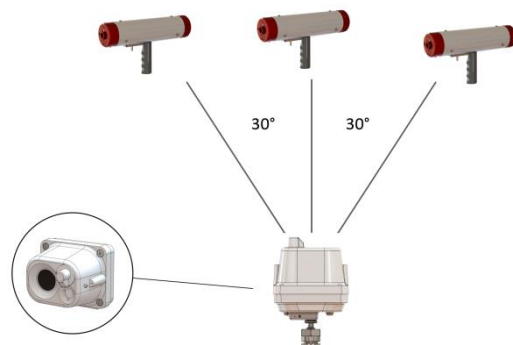

4. Make similar tests from various locations within the protected area, the detector should respond as stated above.

**NOTE:** The portable UV Test unit is designed to check for operation only, not for precision sensitivity testing. This must be accomplished at Firefly AB.



## MAINTENANCE

1. Clean the lens with a soft cloth. Accumulations of dirt or grease will cause faulty operation.

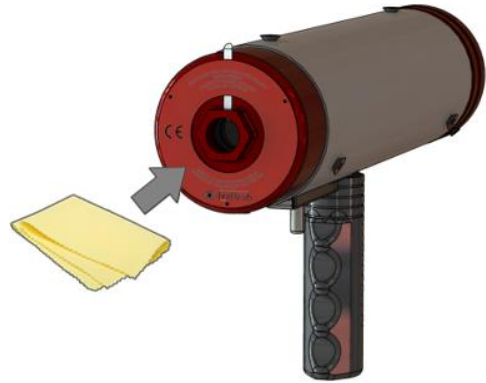

## RECHARGING THE UNIT

1. Loosen the two setscrews and remove the rear end cap.

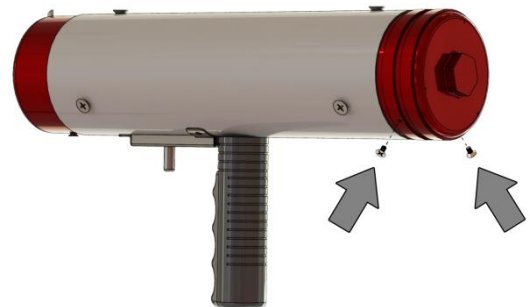

2. First: Extend the cable with the angled M8 contact from its storage in the sleeve, remove the protection cap, and connect it to the supplied battery charger, Firefly P/N 24129.

Second: Connect the charger to a 100-240 50-60 Hz power outlet. Mains cords with different AC-plugs are supplied.

The charger will indicate when the batteries are fully charged. The indication LED on the charger indicates the charge states:

LED color	Charge state
Yellow	Battery not connected
Yellow	Battery initialisation and analysis
Orange	Fast charge
Green led with yellow flash	Top-off charge
Green	Trickle charge, fully charged batteries
Alternating orange-green	Error detected



The charger can stay connected to the NiCd batteries without damaging the batteries. After charging, re-install the protection cap to the angled M8 contact.

More information regarding the charger P/N 24129 on next page.

3. Lightly coat the threads of the end cap with antiseize compound, replace it on the sleeve and secure the setscrews. Make sure all threads on the end cap are engaged before securing setscrews.

**NOTE: ATTEMPT NO REPAIRS ON THE UNIT. A NON-FUNCTIONAL UNIT SHALL BE RETURNED TO FIREFLY AB.**



## NiCD charger, P/N 24129

The charger is designed for indoor use only.

### Charger functionality

This charger is a fast charger for NiCd batteries. It utilizes a method called -dV detection for charge termination when the batteries are fully charged. This method is based on the fact that the voltage drops over the NiCd cells when the batteries are fully charged. This voltage drop is detected when the voltage has dropped a certain percentage from the highest value (typically 0.5%). If this drop does not occur, the charger has a safety timer which

will terminate charging after a given time period to avoid overcharging the batteries. A few cells have a voltage drop in the first part of the charge cycle. This is especially true for battery cells which have been idle for a longer period of time. Because of this, a start-timer is built into the charger which prevents -dV detection the first minutes of the charge cycle.

### How to use the charger

The charger is started by connecting the battery pack to the charger and then connecting the charger to the mains. The LED (light emitting diode) will be yellow before the fast charge starts and the LED changes to orange. When the batteries are fully charged and the voltage drops because of the -dV signal from the batteries, the charger will go into a top-off charge mode before it goes over to trickle charge mode. During top-off charge the LED will be green with a short intermittent yellow light. When the top-off charge is completed, the charger will go into trickle charge mode and the LED will be green. The charge current is now reduced to a safe level, which allows the charger to stay connected to the NiCd batteries without damaging the batteries. If the safety timer runs out before -dV is detected, the charger will go directly to trickle

charge mode (no top-off charge) and LED will be continuously green. If the battery voltage is far below normal, the charger will cut the fast charge current and go to trickle charge mode. The LED will then indicate "error" by flickering green and orange light. If the mains input voltage is turned off, the charger will reset. When the mains input voltage is turned on again a new charge cycle will start.

If new batteries are to be connected, the charger must idle for approx 15 sec. to make sure all parameters in the microprocessor have been reset. When the charger has been reset the LED changes to yellow, and a new charge cycle can begin.

### Charge cycle and LED indications

<i>LED MODE</i>	<i>Description</i>
YELLOW	Battery not connected
YELLOW	Battery initialisation and analysis
ORANGE	Fast charge
GREEN with intermittent YELLOW flash	Top-Off Charge
GREEN	Trickle Charge
Alternating ORANGE-GREEN	ERROR

When the mains is connected the LED will be orange for the first seconds and then turn to yellow when the initialisation and analysis starts. If a battery is connected, the actual charging will start a few seconds later when the LED changes to orange. After the start-timer period has run out (the first few minutes of the charge cycle when the

-dV detection is disabled), the LED will be green for approx. 8 seconds. This is a signal for testing and service only. When -dV has been detected, the start of the top-off charge is indicated with a green LED with intermittent yellow flashes. The LED is green during trickle charge.

### Cautions before charging NiCd batteries

- The charger is designed for charging the NiCd batteries within the 43808-3 test unit only.
- Do not charge the batteries at too high or too low temperatures.
- The charge cycle starts when the charger is connected to the mains.
- If the charger is disconnected from the mains voltage during a charge cycle the charger will start a new charge cycle when it is reconnected to the mains.
- When charging is complete, disconnect the charger from the mains before removing battery connections.